

## SUBMITTAL DATA horizontal steam/hot water unit heaters model HC, side connections

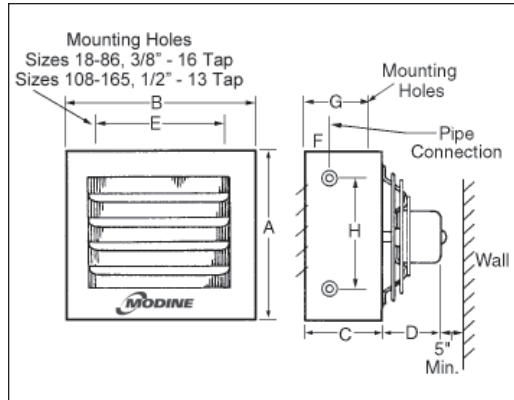

**Canadian  
Registered  
heat exchangers  
CRN  
OH 9234.5**

**Figure 1.1  
Model Dimensions HC18-165**



**Figure 1.2  
Model Dimensions HC193-340 ①**

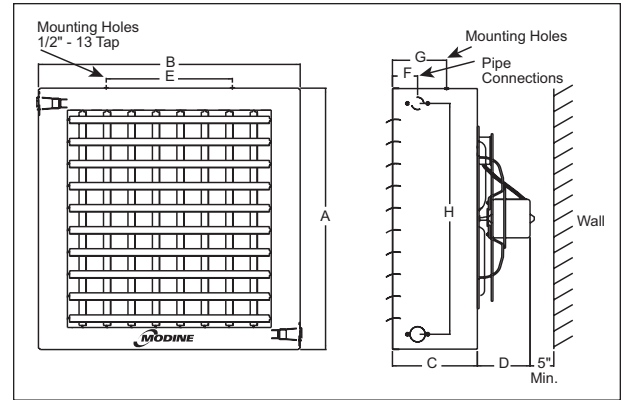

① Vertical deflector blades shown are standard on models HC 258-340 and optional on model HC 193.

**Table 1.1 - Dimensions ①②**

Model No.	A	B	C	D		E	F	G	H	Connections NPT	Shipping Fan Dia.	Approx. Weight (Lb.)
				115V Std. Motor	115V Exp. Motor							
HC-18	11-1/2	12-3/4	6	5	12-1/4	5-5/8	2-1/4	4-1/8	7 1/2	1/2	9	16
HC-24	11-1/2	12-3/4	6	5	12-1/4	5-5/8	2-1/4	4-1/8	7 1/2	1/2	9	20
HC-33	15	17-1/2	8-3/4	6	11-3/4	11	3-5/8	6	10	3/4	12	34
HC-47	15	17-1/2	8-3/4	6	11-3/4	11	3-5/8	6	10	3/4	12	6
HC-63	18-1/2	21-1/2	8-3/4	7 3/4	12	15	3-5/8	6	14	3/4	12	48
HC-86	18-1/2	21-1/2	8-3/4	7 3/4	12	15	3-5/8	6	14	3/4	14	52
HC-108	22-1/2	25-1/2	9-1/2	6 3/4	13-1/4	18	3-5/8	6-3/8	18	3/4	18	74
HC-121	22-1/2	25-1/2	9-1/2	6 3/4	11	18	3-5/8	6-3/8	18	3/4	18	76
HC-165	26-1/2	29-1/2	9-1/4	8	14	21-1/4	3-5/8	6-3/8	22	3/4	22	92
HC-193	30-1/2	32-1/2	9-1/4	8	14	21-1/4	3-5/8	4-3/4	26	1-1/4	22	98
HC-258	38-1/2	38-1/2	12-1/2	10	15	18-5/8	3-5/8	8	34	1-1/4	22	163
HC-290	38-1/2	38-1/2	12-1/2	10	15	18-5/8	3-5/8	8	34	1-1/4	24	168
HC-340	38-1/2	44-1/2	12-1/2	10	15	18-5/8	3-5/8	8	34	1-1/4	24	176

① All dimensions in inches.

② Dimensions shown are for Standard and Low Outlet Temperature models.

**Table 1.2 - Specifications**

Model No.	Core Type		Copper Tube Size (Inches)	Copper Tube Wall Thickness (Inches)
	Single Serpentine	Double Serpentine		
HC-18	X	-	5/8 OD	0.028
HC-24	X	-	5/8 OD	0.028
HC-33	X	-	1 OD	0.030
HC-47	X	-	1 OD	0.030
HC-63	X	-	1 OD	0.030
HC-86	X	-	1 OD	0.030
HC-108	X	-	1 OD	0.030
HC-121	X	-	1 OD	0.030
HC-165	X	-	1 OD	0.030
HC-193	-	X	1 OD	0.030
HC-258	-	X	1 OD	0.030
HC-290	-	X	1 OD	0.030
HC-340	-	X	1 OD	0.030

**Junction Box**

All units include an electrical junction box either integral to the motor or attached to the unit casing. Explosion proof units include an explosion proof junction box attached to the motor.

# 1-456.3 SUBMITTAL DATA

Table 2.1 - Motor Data ①

Model Number	Motor HP	Voltage, Motor Type and Power Code							
		115/60/1	230/60/1	200-208/60/3	230/460/60/3	115/60/1	230/460/60/3	575/60/3	575/60/3
		Totally Enclosed w/Thermal Overload	Totally Enclosed w/Thermal Overload	Totally Enclosed	Totally Enclosed	Explosion Proof w/Thermal Overload	Explosion Proof w/Thermal Overload	Totally Enclosed	Explosion Proof w/Thermal Overload
		01	02	04	05	06	09	10	11
		Amps	Amps	Amps	Amps	Amps	Amps	Amps	Amps
HC-18	1/60	0.8	0.44	-	-	3.1	-	-	-
HC-24	1/25	1.6	0.44	-	-	3.1	-	-	-
HC-33	1/25	1.6	1	-	-	3.1	-	-	-
HC-47	1/12	2.2	1	1.2	1.4/0.7	3.1	-	-	-
HC-63	1/12	2.2	1	1.2	1.4/0.7	3.1	-	-	-
HC-86	1/8	2.3	1	1.2	1.4/0.7	3.1	-	-	-
HC-108	1/8	2.3	1	1.2	1.4/0.7	3.1	-	-	-
HC-121	1/6	2.8	1.5	1.9	2.1/1.05	4.1	1.5/0.75	0.84	-
HC-165	1/3	5.4	2.23	1.9	2.1/1.05	6.1	1.5/0.75	0.84	-
HC-193	1/3	5.4	2.23	1.9	2.1/1.05	6.1	1.5/0.75	0.84	-
HC-258	1/2	7.5	3.5	2.6	3.0/1.5	5.8	2.0/1.0	0.92	0.76
HC-290	1/2	7.5	3.5	2.6	3.0/1.5	5.8	2.0/1.0	0.92	0.76
HC-340	1/2	7.5	3.5	2.6	3.0/1.5	5.8	2.0/1.0	0.92	0.76

① Ratings shown are for Standard and Low Outlet Temperature models.



## Modine Breeze™ AccuSpec Sizing and Selection Program

The Modine Breeze AccuSpec is the fastest way to generate performance data based on actual job conditions. The Breeze AccuSpec program is a Windows based sizing and selection program. The program provides a series of step-by-step questions that allow for the easy configuration of Modine products. After a model has been configured, the program can generate Submittal Schedules, Submittal Data including performance and dimensional drawings, and Specifications.

### Capacities at Job Conditions

Several Model Capacities shown for comparison

Prefix	Model Size	Coil Type	Btu/Hr	GPM	Pressure Drop
C	18	Std	16,673	1.7	0.8
C	24	Std	21,586	2.2	1.3
HS/HC	33	Std	29,154	3.0	0.3
HS/HC	47	Std	41,855	4.4	0.6
HS/HC	63	Std	60,265	6.3	1.0
HS/HC	86	Std	80,034	8.3	1.7
HS/HC	108	Std	110,385	11.5	4.5
HS/HC	121	Std	122,653	12.8	5.5
HS/HC	165	Std	171,064	17.8	13.9

Actual job conditions: Entering Water Temp (100 to 200°F) 225, Entering Air Temp (60 to 100°F) 50

### Pictures for Visual Selection

Horizontal Airflow

Vertical Airflow

### Submittal Schedules

AccuSpec V6.20

**SUBMITTAL SCHEDULE & DATA**

Steam/Hot Water Unit Heaters

Job Name: \_\_\_\_\_ Date: \_\_\_\_\_  
 Location: \_\_\_\_\_ Engineer: \_\_\_\_\_  
 Submitted by: \_\_\_\_\_ Architect: \_\_\_\_\_  
 Contractor: \_\_\_\_\_

Model Number	HS 108S 01	Unit Tag
Quantity of Units	1	
Rated Output	166,000	
GPM	2010	
Outlet Velocity	790	
Entering Air Temp. (°F)	60	
Final Air Temp. (°F)	100	
Fluid Type (Steam or Hot Water)	Steam	
Steam Pressure (PSI)	2	
Condensate (Btuh)	112	
Entering Water Temp. (°F)	N/A	
Water Flow Rate (GPM)	N/A	
Water Pressure Drop (ft of Water)	N/A	
Water Temp. Drop (°F)	N/A	
Supply Voltage	115/60/1	
Motor Type	Totally Enclosed with Thermal Overload	
Motor HP	1/8	

### Unit Specific Dimensional Drawings

Modine AccuSpec V6.20

**DIMENSIONS - UNIT**

Model HS Dimensions

Mounting Holes 1/2" - 13 Tap

Model Size HS 108

Dimensions (in inches)	Value
A	27-1/4
B	27-1/4
C	9-1/2
D	8
E	18
F	3-3/4
G	0-3/8
Connections NPT	1-1/4
Fan Diameter	18

### Job Specific Specifications

**Specifications**

**General**  
 Contractor shall furnish and install Modine steam/hot water unit heaters. Performance shall be as indicated on the equipment schedule in the plans. Unit heaters shall listed by CSA's certified.

**Units**  
 Self-contained, factory assembled, pre-wired unit consisting of cabinet with air deflection louvers, supply fan, motor, and condenser.

**Coating**  
 Exterior surfaces shall be baked on grey-green corrosion resistant, high solids coating that meets the following:  
 1. 500 hours of salt spray as defined in ASTM B117.  
 2. Adhesion/crosshatch tape tests as defined in ASTM D3359, Method B, Rating 5B.  
 3. Will not crack or peel when test panel is bent around a 1/8 inch arc.

**Condenser**  
 Condenser coils are of the extended surface type of serpentine design, utilizing aluminum fins and D.I.P. type copper tubes with malleable iron supply and return connections. Tubes are mechanically bonded to the collars of the fins. The condensers are warranted for operation at steam or hot water pressures up to 160 pounds per square inch gauge and/or temperatures up to 375°F. All coils are leak tested at 160 to 200 psig, air under water. Fins are continuous across the width and depth of the condenser and are vertically oriented to minimize the collection of dirt and dust.

Coils are of serpentine design with horizontal tubes, vertical fins and center supply and return connections at top and bottom of unit. All tube bends are beaded. All tubes have individual expansion bends. Copper tubes are 1" O.D. with 0.03" wall thickness.

**Motor**  
 Single motor with a supply voltage of 115 and horsepower of 1/8 as indicated on the equipment schedule and manufactured in accordance with NEMA standards for continuous fan duty type applications. Must be totally enclosed and single phase motors will have built in thermal overload protection. 3000 RPM, 115/60/1, 1/8 HP, 115/60/1, 1/8 HP, 115/60/1, 1/8 HP. The entire length of the line voltage motor leads will be shielded and terminate in a factory supplied junction box mounted on the unit or integrate to the motor.

For a copy of the Breeze AccuSpec program, contact your local Modine sales representative.