

Horizontal Concentric Vent Installation Supplement

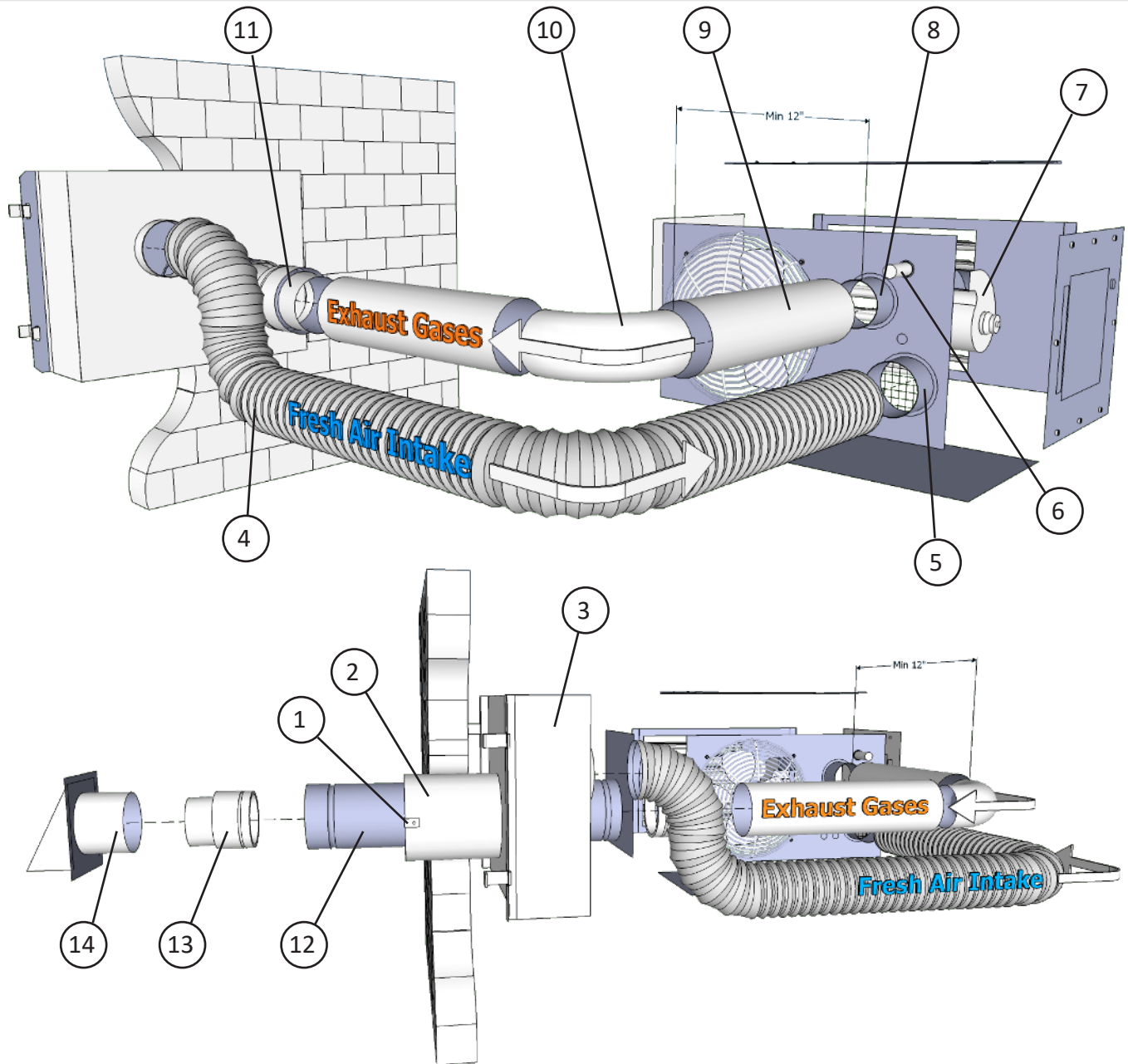

Number	Description	Number	Description
1	Bird Guard	8	Exhaust Vent Pipe Connection ¹
2	Air Intake Vent Pipe (C-Vent) ⁴	9	C-Vent ^{2,4}
3	Horizontal Concentric Vent Box	10	90° Elbow ^{3,4}
4	Aluminum Flex Pipe (or C-Vent) ^{4,5}	11	Draft Hood Connector (C - B) ⁴
5	Combustion Air Inlet Pipe Connection	12	B-Vent (Double-Wall, ¼" Air Gap) ⁴
6	Gas Pipe	13	Reverse Draft Hood Connector (B - C) ⁴
7	Power Exhauster	14	Vent Cap

¹ HDS models 30-45 are factory supplied with 3"-4" vent transitions for attaching the exhaust & air intake pipe to the heater.

² Horizontal sections of vent pipe are to be installed with a minimum downward slope from the appliance of ¼" per foot.

³ Shown as an example. Placement of unit heater in your application may need a 30°, 45°, or any other angle vent.

⁴ All C-Vent, B-Vent, Aluminum Flex Pipe and accessories are field supplied and installed.

⁵ Aluminum Flex Pipe (per local authority) and/or C-Vent (suggested 26 ga.).

Horizontal Concentric Vent Installation Supplement

1 Concentric Adaptor Box
Combustion Air Intake Pipe (C-Vent)
Air Inlet

Slide the Combustion Air Intake Pipe (C-Vent) over the Air Inlet located on the concentric pipe side of the Concentric Adaptor Box.

2

Attach the C-Vent to the air inlet using at least 3 corrosion resistant sheet metal screws. Seal the joint and seam using sealant suitable for temperatures up to 400°F.

3

Exterior side of building wall

Place this assembly (the adapter box and combustion air intake pipe) through the hole in the wall ensuring combustion air intake pipe extends beyond the exterior side of the building wall by 1 " minimum.

4

Brackets

The adapter box can be mounted flush to the wall. The box may also be offset from the wall by using field supplied brackets. If using field supplied brackets, they must be strong enough to rigidly secure the box to the wall and should be made from corrosion resistant material.

5

B-Vent (double-wall, 1/4" air gap)

Insert the B-Vent (double-wall, 1/4" air gap) through the hole on the non-concentric pipe side of the Concentric Adaptor Box, as shown above.

6

Interior side of building wall

From outside the building, caulk the gap between the combustion air intake pipe and the building penetration.

7

Bird Guard

Air Intake Vent

Attach the Bird Guard at the end of the combustion air intake vent, using corrosion resistant screws.

8

Reverse draft Hood Connector (B - C)

B-Vent (double-wall, 1/4" air gap)

Attach the Reverse Draft Hood Connector (B - C) to the outdoor end of the B-Vent (double-wall, 1/4" air gap; preferred for ease of installation).

Horizontal Concentric Vent Installation Supplement

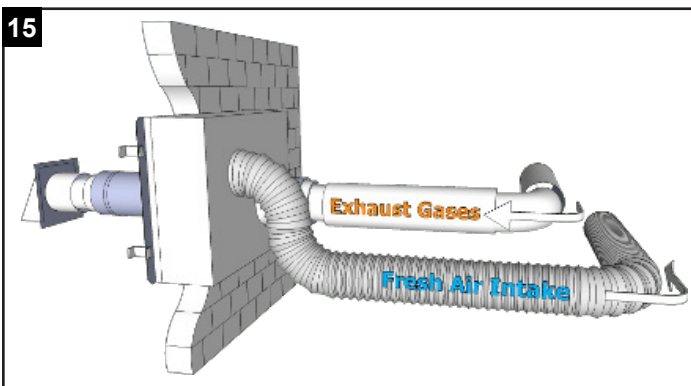
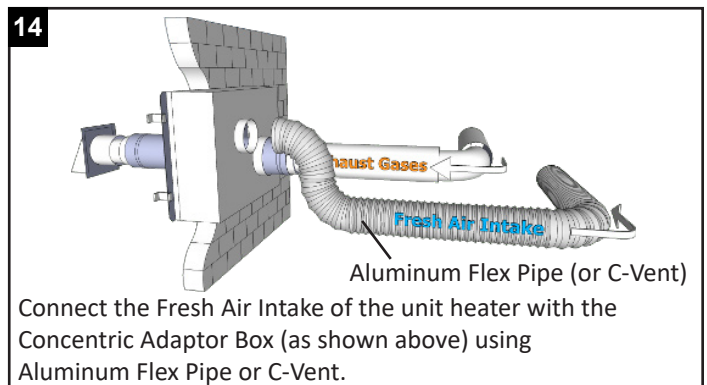
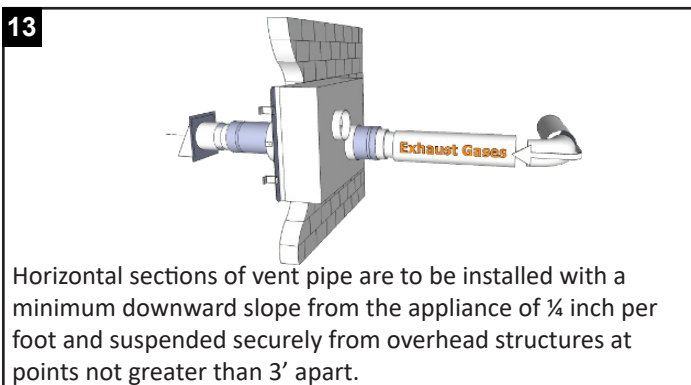
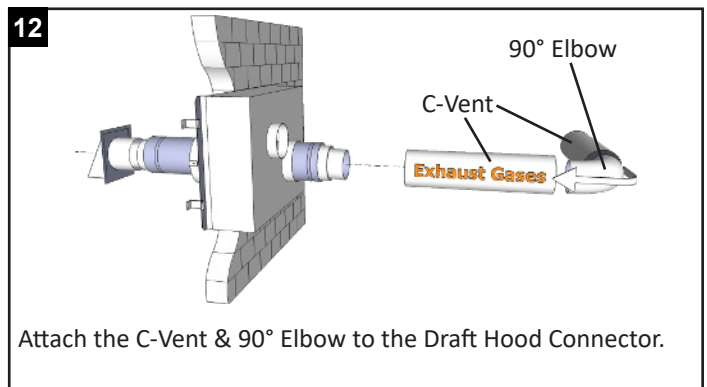
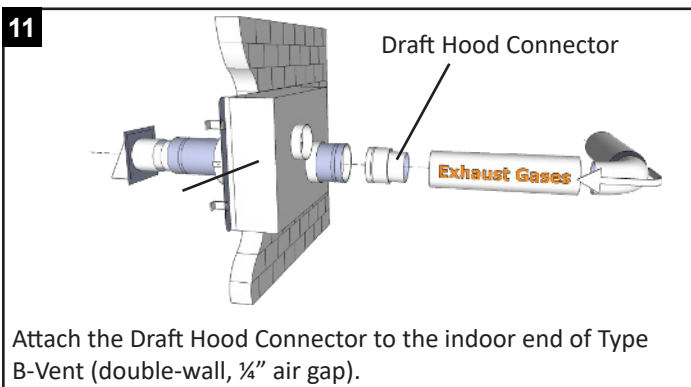
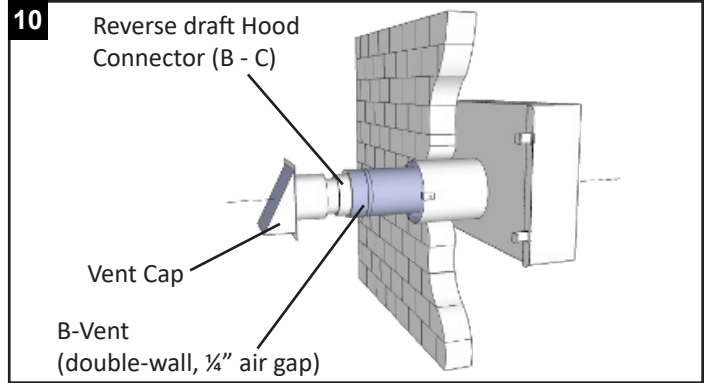
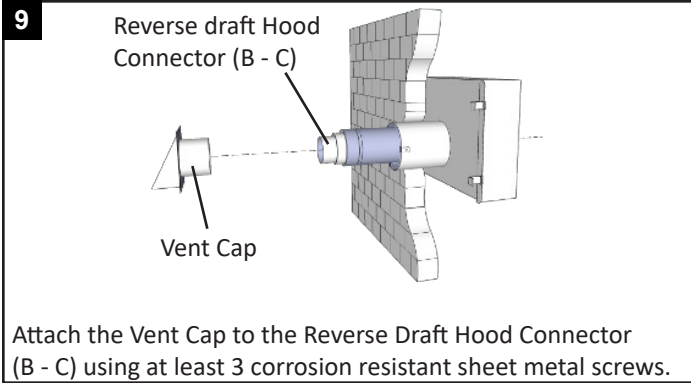

16

Refer to table on the next page for B-Vent, C-Vent and Concentric Adaptor Box dimensions recommended for corresponding unit heater model #s.

All seams and joints must be sealed with either tape, silicone sealant, or other appropriate sealants suitable for metal to metal contact and for temperatures up to 400° F. If using tape, wrap it two full turns around the vent pipe.

A minimum of 12" straight pipe is recommended from the flue outlet before turns in the vent pipe.

Horizontal Concentric Vent Installation Supplement

Fig 1 - Horizontal Concentric Venting Outdoor Clearances

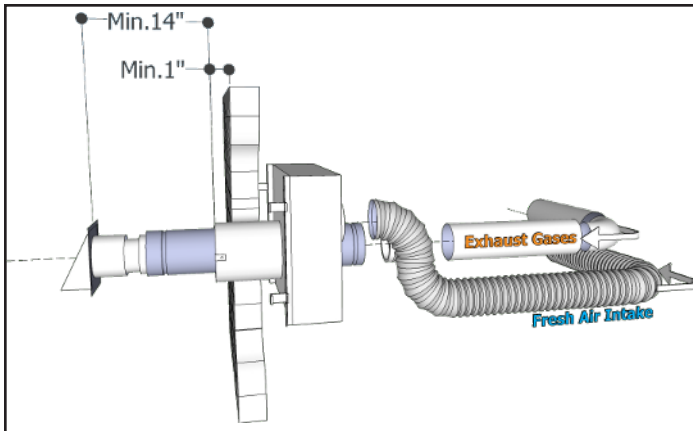
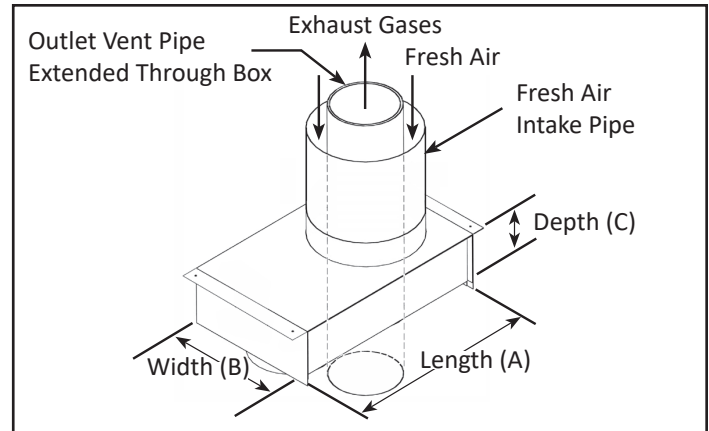

Fig 2 - Concentric Adapter Box with intake pipe attached



Model #	BTU/hr	Kit P/N	Exhaust Pipe ¹		B-Vent Pipe ²		Fresh Air Intake Pipe ³	Concentric Adaptor Box		
			(C-Vent)	ID	OD	Length (A)		Width (B)	Depth (C)	
HDS	30-45	77792 ⁴	3"	4"	4.5"	6"	18.84"	13.33"	4.57"	
HDS/HDC	60-125	32161 ⁵	4"	4"	4.5"	6"	18.84"	13.33"	4.57"	
PTX/BTX ⁶	150-200	32161	4"	4"	4.5"	6"	18.84"	13.33"	4.57"	
PTX/BTX ⁶	250-400	32162	6"	6"	6.5"	8"	15.27"	17.00"	4.57"	
DFS	100-175	32161	4"	4"	4.5"	6"	18.84"	13.33"	4.57"	
DFS	200-400	32162	6"	6"	6.5"	8"	15.27"	17.00"	4.57"	

1 Exhaust pipe from unit heater up to the concentric vent kit adapter box.

2 Opening in the adapter box accepts double-wall B-vent with 1/4" air gap between double-wall B-vent's inner and outer walls.

3 Fresh air intake pipe from the adapter box to the outside of the building. This pipe goes through the hole in the wall.

4 Comes with (2) qty. 3" to 4" transitions for attaching the 3" exhaust pipe to 4" B-vent & 3" fresh air intake pipe to the 4" collar on the adapter box.

5 Same kit as P/N 77792 except that this kit does not include the 3" to 4" transitions.

6 Same data applicable for previous models PTS and BTS.

Horizontal Concentric Vent Kit Components

- A) Exhaust Vent Cap
- B) Bird Guard
- C) Concentric Adapter Box

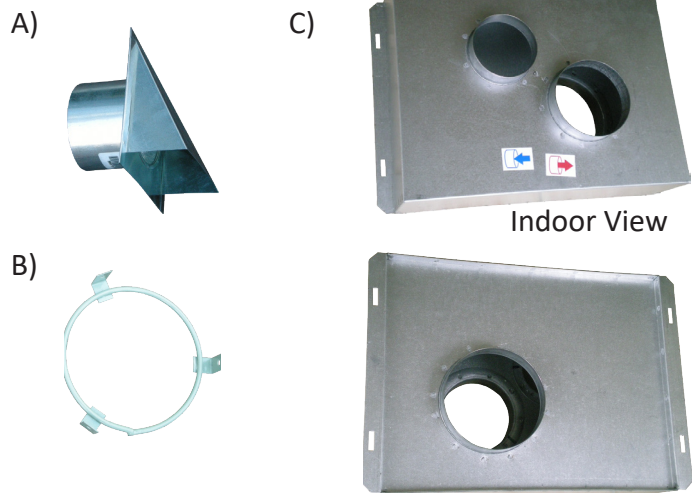

Hydronic HVAC Sales

Tech Support

Sanjeev Khindaria, B.Sc. Tel: 416-716-7332 Email: sanjeev@hydronichvac.com

Philip Antecol, P.Eng. Tel: 416-618-4950 Email: sales@hydronichvac.com

www.HydronicHVAC.com

Disclaimer: This supplement is not an authorized document from Modine Manufacturing. It is strictly a supplement to assist in understanding how the concentric kit is assembled. Please refer to manufacturer's Installation & Operations Manual for detailed instructions.